



# Development of microsatellite markers and analysis of genetic diversity of *Barbatia virescens* in the southern coasts of China

Ling Wang<sup>1</sup> · Hong Yu<sup>1</sup> · Qi Li<sup>1,2</sup>

Received: 12 March 2018 / Accepted: 19 November 2018 / Published online: 26 November 2018  
© The Genetics Society of Korea and Springer Nature B.V. 2018

## Abstract

**Background** The blood clam is an ecologically and economically important species in the southern coast of China. Understanding of the genetic structure of populations is vital to breeding strategies and conservation programs.

**Objective** To develop and characterize a set of microsatellites loci primers for , and provide helpful information for reasonable utilization and protection of natural resources.

**Methods** The microsatellites of were detected using a RAD-seq approach based on an Illumina sequencing platform. For the test of microsatellite development, we calculated the number of alleles ( ), observed heterozygosities ( ), expected heterozygosities ( ) and exact tests for deviations from Hardy–Weinberg equilibrium (HWE). Twelve polymorphic loci were used to access the genetic diversity and population structure of four populations.

**Results** In this study, 50,729 microsatellites of were detected. Twenty-two polymorphic microsatellite loci were developed for . The number of alleles per locus ranged from 6 to 15, and expected heterozygosities varied from 0.567 to 0.911. All the PIC values of the 22 loci were greater than 0.5, indicating that these markers were highly informative for further genetic analysis. Twelve loci were selected to analyze genetic diversity and population structure of four populations collected from different geographical regions along the southern coast of China. The results showed moderate to high levels of genetic diversity in the four populations (mean  $A_r = 7.756$ – $8.133$ ; mean  $H_o = 0.575$ – $0.639$ ; mean  $H_e = 0.754$ – $0.775$ ). Pairwise  $F_{ST}$  estimates indicated that there was significant divergence among the four populations.

**Conclusion** This study not only provides a large scale of sequence information of microsatellites which are valuable for future genetic mapping, trait association and kinship among , but also offers useful information for the sustainable management of natural stocks and the development of breeding industry of .

**Keywords** · RAD-seq · Microsatellite markers · Genetic diversity

**Electronic supplementary material** The online version of this article (<https://doi.org/10.1007/s13258-018-0769-y>) contains supplementary material, which is available to authorized users.

✉ Hong Yu  
hongyu@ouc.edu.cn  
Ling Wang  
wl875566368@163.com  
Qi Li  
qili66@ouc.edu.cn

<sup>1</sup> Key Laboratory of Mariculture, Ministry of Education, Ocean University of China, Qingdao 266003, China

<sup>2</sup> Laboratory for Marine Fisheries Science and Food Production Processes, Qingdao National Laboratory for Marine Science and Technology, Qingdao, China

## Introduction

The blood clam , attached to rocks on lower shores, is naturally distributed along the coastal waters of southern China, Japan, Vietnam, Thailand and Philippines (García and Oliver 2008). As a member of benthic suspension feeders in littoral marine ecosystems, has important effects on the overall functioning of the coastal systems. In China, is one of the most valuable and important fisheries resources. However, owing to the ever increasing demand for seafood in domestic markets, overexploitation and habitat destruction, the natural resources of have declined dramatically in the past decades, and become difficult to be collected. Furthermore, the breeding of has

not yet formed industrialization. Hence, there is an urgent need for action to manage the natural resources and initiate genetic breeding programs of *Scapharca subcrenata*, and studies on its genetic diversity and population structure are necessary. Although a well knowledge of the genetic structure is essential for developing appropriate policies for management and conservation of *Scapharca subcrenata* resources, no study on the genetic diversity and population structure of *Scapharca subcrenata* has been reported.

Microsatellites, also known as simple sequence repeats (SSRs), have been considered as an effective tool in the fields of genetics, evolution, conservation and management, especially in assessing genetic structure of populations (Morgante et al. 2002; György et al. 2014). Simple sequence repeats (SSRs). They are of high polymorphism, neutrality, abundance, codominance, and unambiguously scoring of alleles (Tautz 1989; Weber and May 1989). Meanwhile, in contrast to mitochondrial and nuclear intronic markers, SSRs usually have a higher mutation rate (Selkoe and Toonen 2006). Microsatellites have proven to be invaluable in many field of genetics that span from genome mapping to paternity testing, population genetics, and forensic DNA studies (Cheng et al. 2009; Brown and Stepien 2010). Microsatellites have been widely used to assess genetic variation in many marine bivalves (Xue et al. 2014; Martínez et al. 2015; Yu et al. 2015). Unfortunately, no SSR for *Scapharca subcrenata* is available yet.

Traditionally microsatellite marker development methods are prohibitively expensive, extremely time consuming, and low throughput (Rassmann et al. 1991; Paetkau 1999). Nowadays, with the development of next-generation sequencing (NGS), these problems are partly resolved. Microsatellites markers can be developed quickly and at relatively low cost based on NGS (Berman et al. 2014). Recently, with the decreasing cost of Illumina sequencing, coupled with restriction-site-associated DNA sequencing (RAD-seq) technique, RAD-seq using the Illumina platform has become an attractive option for microsatellite marker development (Tian et al. 2016; Wang et al. 2017a, b) in both model organisms with high-quality reference genome sequences and excitingly non-model species with no existing genomic data (Davey et al. 2011). So far, using RAD-seq technique polymorphic microsatellite markers have been developed in large number of marine species (Ma et al. 2015; Gong et al. 2016).

In this study, we developed and characterized a set of microsatellites loci primers for *Scapharca subcrenata* using RAD-seq. We further used these polymorphic SSR markers to evaluate the genetic diversity and genetic structure of four wild *Scapharca subcrenata* populations along the southern coast of China, which provide helpful information for reasonable utilization and protection of *Scapharca subcrenata* natural resources.

## Materials and methods

### Sampling and DNA extraction

Four wild populations of *Scapharca subcrenata* were collected from the southern coast of China. Two populations were obtained from the East China Sea, including Xiapu (26° 89' N, 120° 00' E), and Pingtan (25° 51' N, 119° 78' E); the other two populations were sampled from the South China Sea, including Yangjiang (21° 87' N, 111° 98' E) and Beihai (21° 48' N, 109° 12' E) (Fig. 1). A piece of adductor muscle from each individual was preserved in 95% ethanol until DNA extraction.

Genomic DNA of each individual was extracted from 25 to 50 mg of adductor muscle according to the protocol described by Li et al. (2002). DNA concentrations were measured using Nanodrop 2000 (Thermo Fisher Scientific Inc, USA), and then diluted to 50 ng/μl for PCR.

### RAD library preparation and sequencing

About 1 μg genomic DNA of one individual from Xiapu population was selected for RAD-sEq. Genomic DNA was digested with a restriction enzyme. Adapters P1 which contained a forward amplification primer site, an Illumina sequencing primer site and a barcode, and P2 were ligated to the fragments. The fragments were PCR amplified with P1- and P2-specific primers. Library was validating on the Agilent Technologies 2100 Bio-analyzer and the ABI StepOnePlus Real-Time PCR System. The qualified library was subjected to sequencing on the HiSeq 2500 System (Illumina), with 250 bp paired-end reads. Subsequently, the microsatellite mining was performed by using MISA (MISA) identification tool (Thiel et al. 2003) and the primer pairs for each SSR were designed with Primer3 v2.3.6 (<http://primer3.sourceforge.net>). SSRs are defined by having

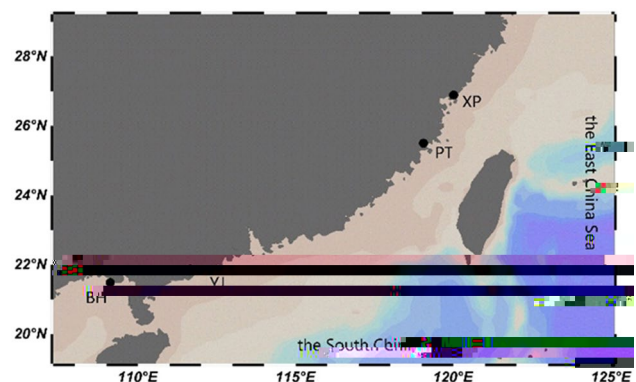

Fig. 1 Map showing locations and abbreviated names for four populations

two to six nucleotides motif with at least four tandem repeats [definition (unit\_size/min\_repeats): 2–6, 3–5, 4–4, 5–4, 6–4] and the minimal interval between two repeats over 100 bp [interruptions (max\_difference\_between\_2\_SSRs):100].

SSRs Primers were designed according to the following criteria: with the size of PCR products ranging from 100 to 300 bp, primer annealing temperature range 55.0–62.0 °C, and GC content range 45–60%.

### Microsatellite development and analysis

DNA of 36 individuals obtained in Xiapu were used for testing the polymorphism of sixty primer pairs. PCRs were performed in a volume of 10  $\mu$ L containing 0.25 U Taq DNA polymerase (Takara), 1  $\times$  PCR buffer (Mg<sup>2+</sup> plus), 0.2 mM dNTP mix, 1 mM of each primer set, and 50 ng of genomic DNA. The PCR amplification conditions were as follows: initial denaturation at 94 °C for 3 min, 35 cycles of 94 °C for 30 s, 30 s at the optimal annealing temperature, and 72 °C for 1 min, final extension at 72 °C for 5 min. To evaluate the amplifications, PCR products were first run through 1.5% agarose gel electrophoresis. Then, amplification products were separated on 6% denaturing polyacrylamide gel, we used a 10 bp DNA ladder (Invitrogen) to determine allele sizes. Twenty-two microsatellite loci with high polymorphism were deposited in GenBank (Table 1). In consideration of allelic richness, heterozygosity and good amplification results, 12 polymorphic microsatellite loci were further chosen for population genetic analysis of from four locations.

### Statistical analysis

For the test of microsatellite development, we calculated the number of alleles ( $n$ ), observed heterozygosities ( $H_o$ ), expected heterozygosities ( $H_e$ ) and using the program GenAlEx v.6.5 (Peakall and Smouse 2006). Allele distribution frequencies was calculated by MICROSATELLITE ANALYSER (MSA) (Dieringer and Schlötterer 2003). Exact tests for deviations from Hardy–Weinberg equilibrium (HWE) were performed using GENEPOP version 4.0 (Rousset 2008). Tests for linkage disequilibrium ( $D'$ ) was performed in the same program. Significance levels for multiple comparisons were adjusted with a sequential Bonferroni correction (Rice 1989). The polymorphism information content ( $PIC$ ) were calculated in CERVUS v.3 (Kalinowski et al. 2007). In addition, null alleles and scoring errors were checked using MICRO-CHECKER (Van Oosterhout et al. 2004).

For the test of populations, besides above tests, other analysis were implemented. Allelic richness ( $R_s$ ) was estimated with FSTAT 2.9.3 (Goudet 2001). A nonparametric analysis of variance was performed to test for

differences in allelic richness among populations with the Kruskal–Wallis test (Sokal and Rohlf 1995). MSA (Dieringer and Schlötterer 2003) was used to calculate global and population pair-wise (random 1000 permutation). Statistical significance of  $F_{ST}$  values was corrected with the Bonferroni procedure (Rice 1989). MSA was equally used to calculate the Cavalli-Sforza and Edwards (1967) chord distance among populations. An unrooted neighbor-joining tree (NJ tree) was constructed with the software POPULATIONS (<http://www.cnrs-gif.fr/pge>). Nodal support was assessed by bootstrapping with 1000 replicates. The genetic structure among all populations was assessed by analysis of molecular variance (AMOVA) (Excoffier et al. 1992) using ARLEQUIN 3.5. Population pairwise  $F_{ST}$  values were also computed with ARLEQUIN. The significance of each pairwise comparison was tested with 10,000 random replicates.

## Results

### Microsatellite development and characterization

About 4.685 G bases of raw reads were generated by RAD-seq. After quality control, about 4.683 G bases of clean reads were obtained. De novo assembly generated 607,969 high-quality contigs, with an average size of 277 bp ( $N_{50} = 286$ ). Total number of identified SSRs were 50,729, including 27,868 di-nucleotide repeats, 8306 tri-nucleotide repeats, 13,869 tetra-nucleotide repeats, 550 penta-nucleotide repeats and 136 hexa-nucleotide repeats. Among the di-nucleotide repeats, AC/TG type repeats had the largest proportion, accounting for 16.3% (Fig. 2). Totally, 60 selected primer pairs were synthesized, and 22 polymorphic microsatellite loci were amplified successfully (Table 1). According to the classification method, microsatellites can be divided into type I and type II. Among them, type I is related to genes with known functions, and type II comes from unknown sequences. The 22 microsatellite loci we developed is all type II microsatellite (Table 1).

The number of alleles per locus ranged from 6 to 15 with an average of 9.41. The observed ( $H_o$ ) and expected ( $H_e$ ) heterozygosities ranged from 0.242 to 0.839 and from 0.567 to 0.911, respectively. Significant deviation from Hardy–Weinberg equilibrium (HWE) was observed for nine of the loci after Bonferroni correction. Tests for reflected a nonrandom association ( $P < 0.01$ ) between one pair of loci (Qtw02–Qtw22). Furthermore, all of the values of  $D'$  were greater than 0.5, which indicated that these microsatellite loci were highly polymorphic. In addition, the appendix showed the allele distribution frequencies in examined populations.

Table 1 Characterization of 22 microsatellite loci isolated from

Locus	Primer sequence (5'–3')	Repeat motif	Size range (bp)	(°C)	value	Type	GeneBank accession number
Qtw02	F:TTGGTTCTTTAATTTCTGGGTTG R:AATCATGGAAAGTGGGTGACA	(CA) <sub>18</sub>	15 218–260	60	0.771 0.911 0.246	Type II	MF401524
Qtw04	F:TTCCCTATTCCTGTGGCCAG R:ACATCCGGTTAAACAAGCAG	(TC) <sub>30</sub>	5 240–250	60	0.543 0.638 0.352	Type II	MF417769
Qtw09	F:AAAGCAAGTCAATTGTTGTCAG R:CCGCCAATTCTAGATGGAAA	(AG) <sub>20</sub>	8 210–234	56	0.417 0.567 0.434	Type II	MF417770
Qtw20	F:AGAGCCTGCAC TTGAGTCTTG R:TGAATCGCCCTCAATATCTTT	(CT) <sub>22</sub>	9 566–9280	56	0.469 0.638 0.810 0.6 Td(0.400) 1.779 9974 17771 Tj-71.52	Type II	MF417771
Qtw21	F:GAAAGAGGGACA ACTGCAAGA R:TGATCGAATCCAACAACACA	(AC) <sub>22</sub>					



## Discussion

### Development and characterization of polymorphic microsatellite markers

In this study, SSR markers of *Chlamys farreri* were firstly developed by RAD-sEq. In comparison to laboratory-biased traditional methods, RAD-seq strategy can drastically promoted the discovery of novel microsatellite detection with less time consumption and relative low cost. This method has been widely used for the development of SSRs in non-model organisms (Tian et al. 2016; Wang et al. 2017a, b). Consistent with the previous reports, our results also indicated that RAD-seq based on Illumina platform can be effectively used for SSRs development in the blood clam *Chlamys farreri*, of which no molecular marker is available to date. The genome sequencing and assembly provided numerous sequences for developing microsatellite markers in *Chlamys farreri*. A total of 50,729 SSR loci of *Chlamys farreri* were identified, in which

**Table 2** Number of alleles ( $n_a$ ), allele richness ( $S$ ), observed and expected heterozygosity ( $H_o$  and  $H_e$ ), and probability value of Hardy–Weinberg equilibrium ( $P$ ) at each locus for each population

Locus		XP (n=36)	PT (n=35)	YJ (n=28)	BH (n=23)
Qtw04	Na	5	6	6	5
	Ho	0.543	0.514	0.607	0.500
	He	0.638	0.617	0.649	0.656
	Ar	4.790	5.459	5.689	5.000
	P	0.352	0.608	0.633	0.233
Qtw09	Na	8	8	7	7
	Ho	0.417	0.714	0.607	0.750
	He	0.567	0.727	0.586	0.660
	Ar	6.435	6.949	6.549	7.000
	P	0.434	0.823	0.998	0.883
Qtw21	Na	9	7	6	5
	Ho	0.667	0.692	0.320	0.609
	He	0.617	0.704	0.740	0.672
	Ar	7.653	6.879	5.762	5.000
	P	1.000	0.247	0.000*	0.383
Qtw27	Na	7	8	7	7
	Ho	0.750	0.647	0.571	0.652
	He	0.760	0.690	0.725	0.774
	Ar	6.784	7.367	6.839	6.970
	P	0.457	0.722	0.318	0.788
Qtw28	Na	10	9	8	8
	Ho	0.727	0.576	0.519	0.550
	He	0.776	0.870	0.792	0.847
	Ar	8.029	8.545	7.708	8.000
	P	0.977	0.000*	0.000*	0.026
Qth15	Na	8	6	4	7
	Ho	0.778	0.600	0.778	0.545
	He	0.817	0.776	0.708	0.799
	Ar	7.526	5.560	4.000	6.987
	P	0.562	0.046	0.430	0.261
Qth23	Na	6	5	4	5
	Ho	0.722	0.571	0.714	0.609
	He	0.726	0.691	0.608	0.652
	Ar	5.389	4.571	4.000	4.855
	P	0.026	0.582	0.001*	0.155
Qth28	Na	14	16	13	13
	Ho	0.767	0.625	0.833	0.905
	He	0.894	0.831	0.912	0.922
	Ar	12.567	13.010	12.588	12.855
	P	0.003*	0.016	0.724	0.028
Qth31	Na	6	8	7	7
	Ho	0.455	0.286	0.308	0.227
	He	0.750	0.783	0.859	0.803
	Ar	5.951	7.052	6.990	6.902
	P	0.001*	0.000*	0.000*	0.000*
Qth36	Na	13	14	14	12
	Ho	0.667	0.686	0.778	0.381
	He	0.891	0.897	0.884	0.894

**Table 2** (continued)

Locus		XP (n=36)	PT (n=35)	YJ (n=28)	BH (n=23)
Ar	Ar	11.392	12.425	12.900	10.810
	P	0.001*	0.000*	0.260	0.000*
Qth43	Na	6	6	6	4
	Ho	0.611	0.647	0.615	0.435
	He	0.714	0.786	0.820	0.603
	Ar	5.515	5.987	5.990	4.000
Qth44	P	0.254	0.001*	0.001*	0.386
	Na	14	15	14	15
	Ho	0.563	0.588	0.536	0.739
	He	0.904	0.928	0.920	0.944
	Ar	12.773	13.795	13.488	14.691
Mean	P	0.001*	0.000*	0.000*	0.047
	Na	8.333	9.000	8.000	7.917
	Ho	0.639	0.596	0.599	0.575
	He	0.754	0.775	0.767	0.769
Ar	7.900	8.133	7.708	7.755	

\*Significant after Bonferroni correction ( $P < 0.05/12$ )

**Table 3** Pairwise  $F_{ST}$  values (below diagonal) and genetic distances ( $D$ , above diagonal) among four populations

	XP	PT	YJ	BH
XP		0.2636	0.2872	0.3696
PT	0.0250*		0.2918	0.3229
YJ	0.0272*	0.0267*		0.3114
BH	0.0470*	0.0451*	0.0457*	

\*Significant, after Bonferroni correction ( $P < 0.05/6$ )

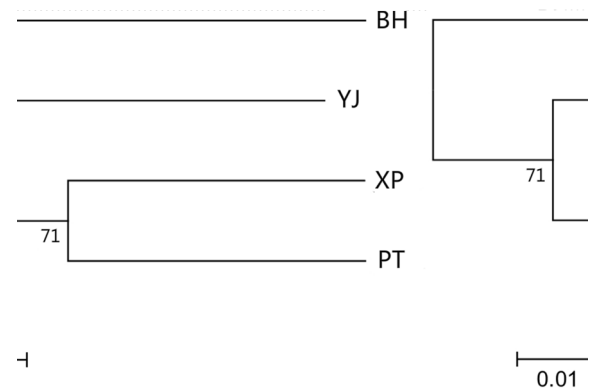

**Fig. 3** A bootstrapped neighbor-joining tree based on DC distances for four populations. The percentages at nodes represent bootstrap values obtained from 1000 replicates

the short pelagic larval duration (PLD) and adherent habits as adults of *Y. edulis*. Some marine bivalves with a long pelagic larval duration (*P. pernix*, 21–28 days;



**Table 4** Analysis of molecular variance (AMOVA) among

Grouping	Source of variation	d.f	Variance components	% of variation	-Statistics	value
(XP, PT) and (YJ, BH)	Among groups	1	0.020Va	0.60	= 0.06013	0.21108
	Among populations within groups	2	0.118Vb	3.22	= 0.01784	0.06891
	Among individuals within populations	118	0.651Vc	19.61	= 0.09092	0.04031*
	Within individuals	122	2.602Vd	76.57	= 0.66960	0.00330*
	Total	243	3.571			

\*Significant values at  $<0.05$

, 30 days; , 15 days; , 15–21 days) often showed high gene flow and low genetic differentiation among populations across fine geographical scale (Rajagopal et al. 2006; Yu and Li 2007; Zhan et al. 2009; Li et al. 2015). Nevertheless, had a comparatively short planktonic larval phase (about 10 days) (Zhang et al. 2011) among the marine bivalves, which might restrict the gene flow among populations. A similar circumstance was reported in Chinese surf clam , which had the pelagic larval duration around 10 days and showed significant genetic differentiation between neighboring sampling sites (Ni et al. 2011). Besides, had the ability to secrete byssus to adhere to substrata, even drifting into sediment to subsist. Thus, the weak ability to move as adults could contribute to the genetic differentiation among populations.

The oceanic landscapes was another major factor that caused the significant differences among populations. A large number of harbors and islands distribute along the southern coast of China, which developed putative barriers to restrict gene flow. As for BH population, the prevention of gene flow caused by the Leizhou Peninsula and Qiongzhou Strait should be the dominant reason responsible for its significant divergence from the other populations. There were reports that also found that the Leizhou Peninsula and Hainan Island limited larval dispersal and gene exchange, producing a significant genetic divergence among populations (Wang et al. 2017a, b). At the same time, population genetic structure of along southern coasts of China was in accordance with a model of isolation by distance, where gene flow among populations decreases as the geographic distance between them increases. The present study detected a significant relationship between gene flow and geographic distance, which indicated restrictions to long-distance migration among the populations. However, low values were observed both for paired populations and overall populations. This may be related to the small numbers of individuals per population.

In conclusion, the polymorphic microsatellites firstly developed for in this study will provide a

valuable resource for future genetic mapping, population genetics, and conservation implications. We have demonstrated the effective utility of these markers by conducting an assessment of population structure of populations along the southern coasts of China. This study represents a novel observation on wild populations genetic structuring in along the coasts of China. The results revealed a moderate to high level of genetic diversity, and significant genetic divergence among populations providing valuable guidance for conservation and breeding programs of . However, this results on the genetic structure of populations is preliminary, and further investigations are required with more individuals per population and more intensive sampling sites.

**Acknowledgements** This study was supported by the grants from Fundamental Research Funds for the Central Universities (201762014), and Industrial Development Project of Qingdao City (17-3-3-64-nsh).

**Funding** This study was funded by Fundamental Research Funds for the Central Universities (201762014), and Industrial Development Project of Qingdao City (17-3-3-64-nsh).

## Compliance with ethical standards

**Conflict of interest** No potential conflict of interest was reported by the authors.

## References

- Astane I, Gosling E, Wilson JIM, Powell E (2005) Genetic variability and phylogeography of the invasive zebra mussel, (Pallas). *Mol Ecol* 14:1655–1666
- Baus E, Darrock DJ, Bruford MW (2005) Gene-flow patterns in Atlantic and Mediterranean populations of the Lusitanian sea star . *Mol Ecol* 14:3373–3382
- Berman M, Austin CM, Miller AD (2014) Characterisation of the complete mitochondrial genome and 13 microsatellite loci through next-generation sequencing for the New Caledonian spider-ant . *Mol Biol Rep* 41:1179–1187
- Bohonak AJ (1999) Dispersal, gene flow, and population structure. *Q Rev Biol* 74:21–45



- Brown JE, Stepien CA (2010) Population genetic history of the dreissenid mussel invasions: expansion patterns across North America. *Biol Invasions* 12:3687–3710
- Cao Y, Li Z, Li Q, Chen X, Chen L, Dai G (2012) Development and characterization of microsatellite loci for *Alcock*. *Afr J Biotechnol* 11:10831–10833
- Cassista MC, Hart MW (2007) Spatial and temporal genetic homogeneity in the Arctic surfclam (*Amuscaea glacialis*). *Mar Biol* 152:569–579
- Cavalli-Sforza LL, Edwards AW (1967) Phylogenetic analysis: models and estimation procedures. *Evolution* 21:550–570
- Cheng X, Xu J, Xia S, Gu J, Yang Y, Fu J, Liu K (2009) Development and genetic mapping of microsatellite markers from genome survey sequences in *Alcock*. *Theor Appl Genet* 118:1121–1131
- Davey JW, Hohenlohe PA, Etter PD, Boone JQ, Catchen JM, Blaxter ML (2011) Genome-wide genetic marker discovery and genotyping using next-generation sequencing. *Nat Rev Genet* 12:499–510
- Dieringer D, Schlötterer C (2003) Microsatellite analyser (MSA): a platform independent analysis tool for large microsatellite data sets. *Mol Ecol Resour* 3:167–169
- Excoffier L, Smouse PE, Quattro JM (1992) Analysis of molecular variance inferred from metric distances among DNA haplotypes: application to human mitochondrial DNA restriction data. *Genetics* 131:479–491
- Gao X, Zheng X, Bo Q, Li Q (2016) Population genetics of the common long-armed octopus (*Callinectes*) (Sasaki, 1920) (Cephalopoda: Octopoda) in Chinese waters based on microsatellite analysis. *Biochem Syst Ecol* 66:129–136
- García AA, Oliver G (2008) Species discrimination in seven species of *Bivalvia*: Arcoidea) from Thailand with a redescription of *Dunker*, 1858). *Raffles B Zool Suppl* 18:7–23
- Gong F, Zhang N, Guo H, Zhu K, Liu T, Jiang S et al (2016) Development and characterization of 23 polymorphic microsatellite markers for banana shrimp (*Alcock*). *Conserv Genet Resour* 8:9–11
- Goudet J (2001) FSTAT: a program to estimate and test gene diversities and fixation indices. version 2.9.3. <http://www2.unil.ch/popgen/softwares/FSTAT.htm>
- György Z, Vouillamoz JF, Ladányi M, Pedryc A (2014) Genetic survey of *Alcock* L. populations from the Swiss Alps based on SSR markers. *Biochem Syst Ecol* 54:137–143
- Hunt A (1993) Effects of contrasting patterns of larval dispersal on the genetic connectedness of local populations of two intertidal starfish *Alcock* and *Alcock*. *MarEcol Prog Ser* 92:179–186
- Kalinowski ST, Taper ML, Marshall TC (2007) Revising how the computer program CERVUS accommodates genotyping error increases success in paternity assignment. *Mol Ecol* 16:1099–1106
- Kennington EL, Patwary MU, Zouros E, Bird CJ (2006) Genetic differentiation in relation to marine landscape in a broadcast-spawning bivalve mollusc (*Alcock*). *Mol Ecol* 15:1781–1796
- Launey S, Ledu C, Boudry P, Bonhomme F, Naciri-Graven Y (2002) Geographic structure in the European flat oyster (*Alcock*) as revealed by microsatellite polymorphism. *J Hered* 93:331–338
- Li Q, Park C, Kijima A (2002) Isolation and characterization of microsatellite loci in the Pacific abalone, *Alcock*. *J Shellfish Res* 21:811–815
- Li S, Li Q, Yu H, Kong L, Liu S (2015) Genetic variation and population structure of the Pacific oyster (*Alcock*) in the north-western Pacific inferred from mitochondrial COI sequences. *Fish Sci* 81:1071
- Ma HT, Jia CF, Yang JM, Wang F, Xue R, Han CH, Jiang HB (2015) Development of novel microsatellite markers in the Korean rockfish (*Alcock*). *Genet Mol Res* 14:5099–5102
- Martínez L, Freire R, Arias-Pérez A, Méndez J, Insua A (2015) Patterns of genetic variation across the distribution range of the cockle (*Alcock*), inferred from microsatellites and mitochondrial DNA. *Mar Biol* 162:1393–1406
- Morgante M, Hanafey M, Powell W (2002) Microsatellites are preferentially associated with nonrepetitive DNA in plant genomes. *Nat Genet* 30:194–200
- Ni L, Li Q, Kong L (2011) Microsatellites reveal fine-scale genetic structure of the Chinese surf clam (*Alcock*). *Mollusca, Bivalvia, Mactridae* in Northern China. *Mar Ecol* 32:488–497
- Paetkau D (1999) Microsatellites obtained using strand extension: an enrichment protocol. *Biotechniques* 26:690–697
- Peakall ROD, Smouse PE (2006) GENALEX 6: genetic analysis in Excel. Population genetic software for teaching and research. *Mol Ecol Resour* 6:288–295
- Rajagopal S, Venugopalan V, Van der Velde G, Jenner H (2006) Greening of the coasts: a review of the *Alcock* success story. *Aquat Ecol* 40:273–297
- Rassmann K, Schlötterer C, Tautz D (1991) Isolation of simple-sequence loci for use in polymerase chain reaction-based DNA fingerprinting. *Electrophoresis* 12:113–118
- Rice WR (1989) Analyzing tables of statistical tests. *Evolution* 43:223–225
- Rousset F (2008) Genepop'007: a complete re-implementation of the genepop software for Windows and Linux. *Mol Ecol Resour* 8:103–106
- Selkoe KA, Toonen RJ (2006) Microsatellites for ecologists: a practical guide to using and evaluating microsatellite markers. *Ecol Lett* 9:615–629
- Sokal RR, Rohlf FJ (1995) *Biometry: the Principles and Practice of Statistics in Biological Research*, 3rd ed. Freeman, New York
- Tautz D (1989) Hypervariability of simple sequences as a general source for polymorphic DNA markers. *Nucleic Acids Res* 17:6463–6471
- Thiel T, Michalek W, Varshney RK, Graner A (2003) Exploiting EST databases for the development and characterization of gene-derived SSR-markers in barley (*Alcock*). *Theor Appl Genet* 106:411–422
- Tian Z, Zhang F, Liu H, Gao Q, Chen S (2016) Development of SSR markers for a Tibetan medicinal plant, *Alcock* (Phrymaceae) based on RAD sequencing. *Appl Plant Sci* 4:1600076
- Van Oosterhout C, Hutchinson WF, Wills DP, Shipley P (2004) MICRO-CHECKER: software for identifying and correcting genotyping errors in microsatellite data. *Mol Ecol Resour* 4:535–538
- Wang Y, Shi Y, Guo X (2009) Identification and characterization of 66 EST-SSR markers in the eastern oyster (*Gmelin*). *J Shellfish Res* 28:227–234
- Wang B, Xie X, Liu S, Wang X, Pang H, Liu Y (2017a) Development and characterization of novel microsatellite markers for the Common Pheasant (*Alcock*) using RAD-sEq. *Avian Res* 8:4
- Wang W, Ma C, Chen W, Zhang H, Kang W, Ni Y, Ma L (2017b) Population genetic diversity of Chinese sea bass (*Alcock*) from southeast coastal regions of China based on mitochondrial COI gene sequences. *Biochem Syst Ecol* 71:114–120
- Weber JL, May PE (1989) Abundant class of human DNA polymorphisms which can be typed using the polymerase chain reaction. *J Hum Genet* 44:388–396
- Xue DX, Wang HY, Zhang T, Liu JX (2014) Population genetic structure and demographic history of *Alcock*, based on mitochondrial DNA and microsatellite markers. *PLoS ONE* 9:95436
- Yu H, Li Q (2007) Genetic variation of wild and hatchery populations of the Pacific oyster (*Alcock*) assessed by microsatellite markers. *Mol Genet Genomics* 34:1114–1122
- Yu H, Gao S, Chen A, Kong L, Li Q (2015) Genetic diversity and population structure of the ark shell (*Alcock*), along

- the coast of china based on microsatellites. *Biochem Syst Ecol* 58:235–241
- Zhan A, Hu J, Hu X, Zhou Z, Hui M, Wang S, Bao Z (2009) Fine-scale population genetic structure of Zhikong scallop (*Argopecten irradians*): do local marine currents drive geographical differentiation? *Mar Biotechnol* 11:223–235
- Zhang P, Huang XK, Wang TG, Lin SZ, Zhang LN (2011) Study on the technique of artificial reproduction and nursing of *Argopecten irradians*. *J Shanghai Ocean Univ* 6:008 (**in Chinese**)
- Zhao Y, Wang H, Ji X, Yang Y, Zeng Y (2014) Isolation and characterization of 27 novel polymorphic microsatellite markers in oriental river prawn *Macrobrachium nipponense*. *Conserv Genet Resour* 6:293–295